

500-1000 Keyless Entry CAN System (Unsealed)



TriMark's Keyless Entry CAN systems consist of a selection of compatible components that allow for complete keyless entry for on or off-highway vehicle applications

DESIGNED FOR:

- Incorporation into TriMark mechanical latches, handles and systems by providing keyless entry, security and convenience for access door systems through a RF remote fob electronics interface and a security touch pad

510-0200 CAN Controller (Unsealed):

- Keyless-entry security and convenience for access door systems through an electrical interface that includes both a touch pad and remote fob transmitter for the ultimate in end user convenience and functionality
- Easy and intuitive to operate
- Rugged and durable construction
- Compliant to on-road, off-road, and industrial environmental requirements
- Increased vehicle security with multiple triggers and outputs
- I/O module with on-board locking and unlocking relays
- Can control up to 20+ entry/compartments doors (expandable)
- Independent control of multiple door zones
- Staggered door control for minimized current draw
- SAE J1939 at 250K/500K or RVC to enable communications with other modules
- Locking/unlocking confirmation
- Lighting and auxiliary output control
- Ability to provide four OEM definable functions from keypad, including ability to unlock one side of motor home baggage doors at a time
- Three security system inputs (ability to sense entry door(s) and baggage door(s), and other security system devices such as glass break and motion detectors)
- Variable timed light activation output (porch, compartment or interior lighting)



530-0100 e-FOB Transmitter

- Reliable radio frequency (RF) transmission
- High security with code hopping technology
- Compliant to FCC-Part 15 and EU RF requirements
- 4-button standard fob (other configurations available)
- Customized graphics possible (buttons and logos)
- Can add up to 10 fob transmitters per vehicle

Global Locations:

TriMark Corporation
500 Bailey Avenue
P.O. Box 350
New Hampton, Iowa 50659
United States
Tel: 641-394-3188
Fax: 641-394-2392
1-800-447-0343
www.trimarkcorp.com

TriMark Europe
Unit 3
Sence Court
Bardon Hill
Coalville LE67 1GZ
United Kingdom
Tel: +44(0)1530 512460
Fax: +44(0)1530 512461
www.trimarkeu.com

TriMark (Xuzhou)
Building A5 Jingwu Road
Xuzhou Economic
Development Zone
Xuzhou, Jiangsu
221004 PR China
Tel: +86 516 8773 0018
Fax: +86 516 8773 0058
www.trimarkcn.com



TriMark. Interactive. Product. Selector



TriMark



TriMark Corporation



TriMark Corporation

AVAILABLE:

- Standard kit make up includes: Two pre-trained RF remote fob transmitters, IO module, and manual
- Optional kits can include: any wiring harnesses for all connection points of system, extra relays, switches, door contacts, actuators, mounting hardware, mounting brackets, door latches, and door paddle handles
- Fob transmitters with independent entry and compartment control
- Fob transmitter with control of auxiliary features
- Vertical and horizontal keypad
- Customized wire harnesses
- Additional fob transmitters
- Two different programming functions; standard mode, and cargo mode. Modes provide customized remote fob transmitter use. Standard mode allows for the lock/unlocking of doors plus panic mode and one auxiliary output (controls lighting, opens compartment etc.). Cargo mode allows for the lock/unlocking of main personnel doors plus independent control of many cargo/compartment doors.

INSTALLATION:

- I/O module is easily installed with (2) #10 or M5 Fastener (not included) and can be mounted in a concealed location
- Keypad is easy to install with (2) #8 or M4 flat head screws (not included)
- Keypad can be installed in a wide range of locations in door — either horizontal or vertical orientation
- Standard 12V DC power
- Easy to install and program

Please refer to individual product codes and part drawings for complete dimensions, specifications, installation procedures, and related items. Engineering assistance and application drawings are available.

U.S. Patent No. 6,789,003 / 7,034,655 / 7,119,709 / 8,350,669

Design Patent No. D590,780

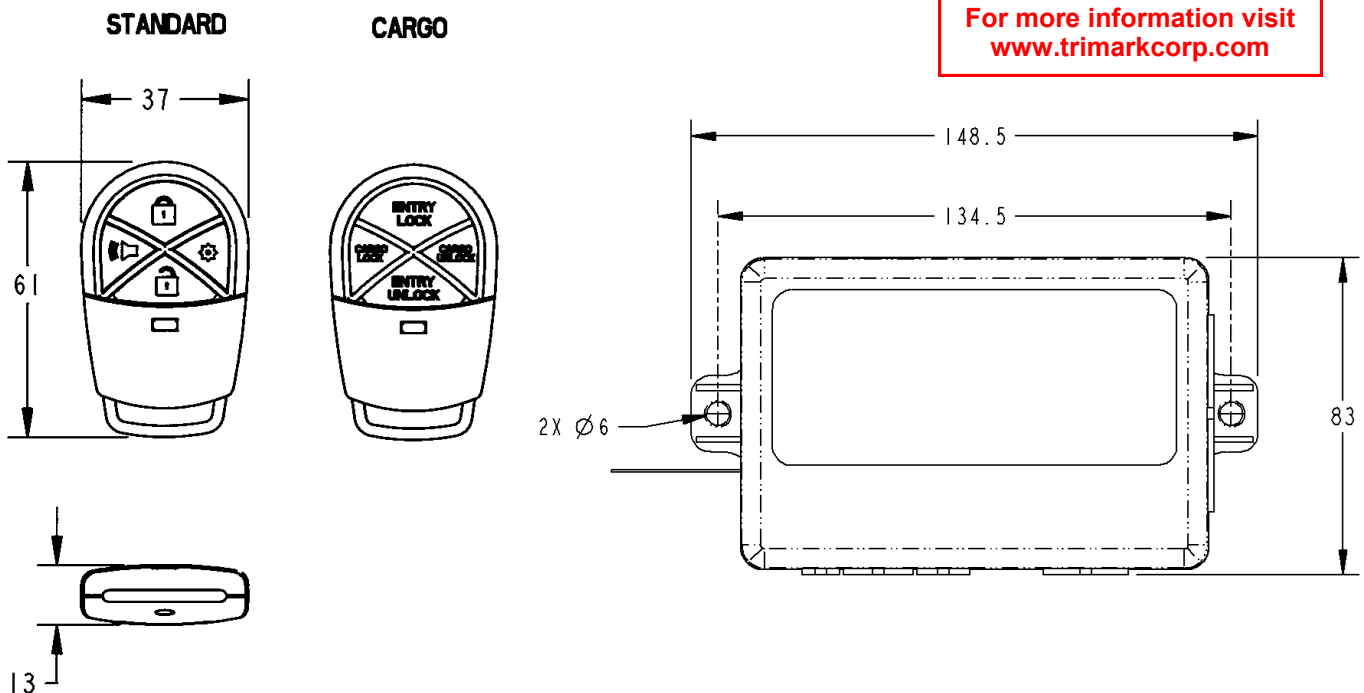

For more information visit
www.trimarkcorp.com

WARNING:

Immediately dispose of used batteries and keep away from children. Do NOT dispose of batteries in household trash.

Even used batteries may cause severe injury or death.

Call a local poison control center for treatment information.

⚠ WARNING

- **INGESTION HAZARD:** This product contains a button cell or coin battery.
- **DEATH** or serious injury can occur if ingested.
- A swallowed button cell or coin battery can cause **Internal Chemical Burns** in as little as **2 hours**.
- **KEEP** new and used batteries **OUT OF REACH OF CHILDREN**
- **Seek immediate medical attention** if a battery is suspected to be swallowed or inserted inside any part of the body.

